

2021 THE TEXAS FESTIVAL HORSE SHOW

AMATEUR L2,L3 AND SELECT L2,L3
YOUTH L2,L3 AND SENIOR L2,L3

SATURDAY APRIL 24TH

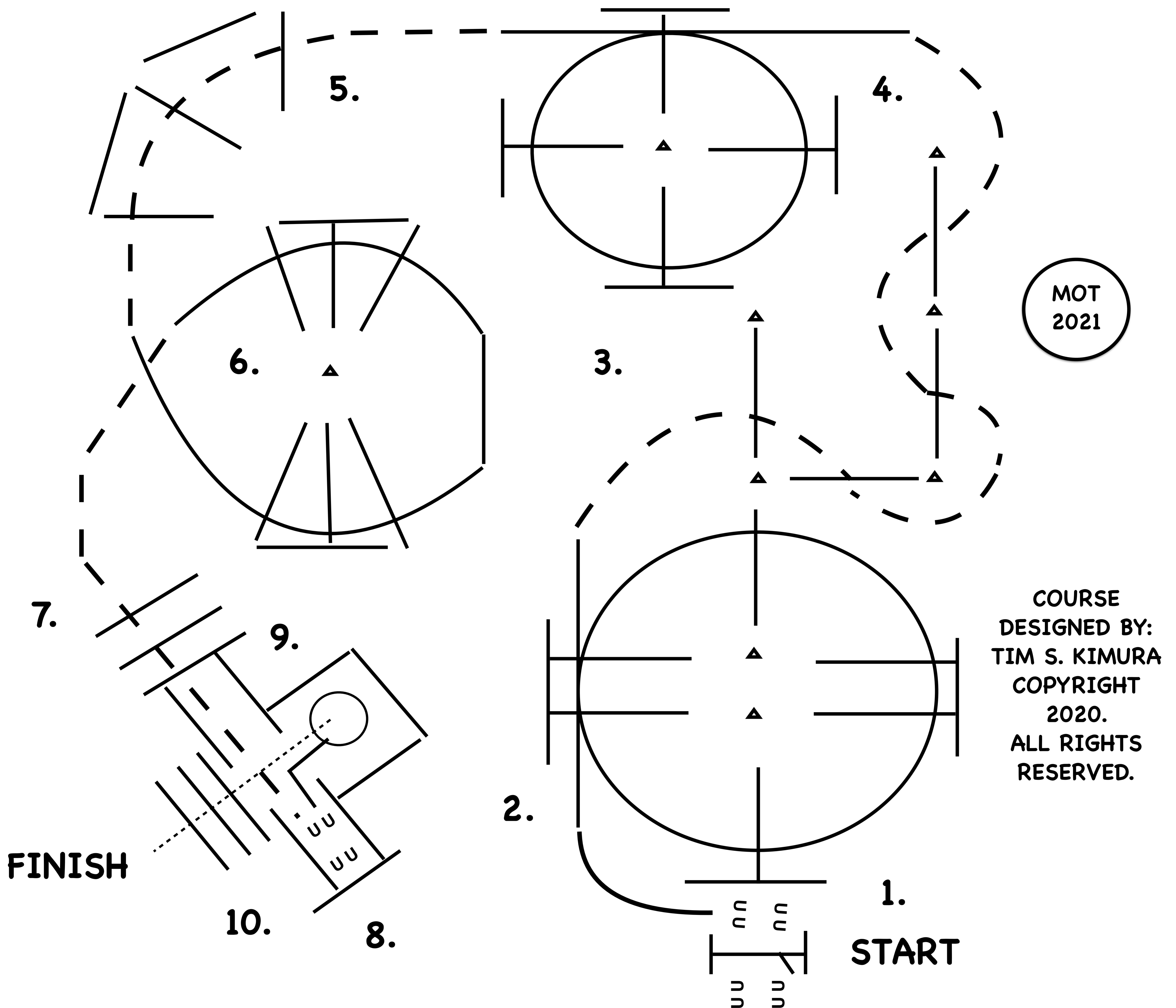

1. ROPE GATE: LEFT HAND OPEN, WALK OVER POLE CLOSE GATE
2. LOPE OVER POLES (RL)
3. BREAK TO THE JOG, JOG THROUGH SERPENITINE, JOG OVER POLES.
4. LOPE OVER POLES (LL).
5. BREAK TO THE JOG, JOG OVER POLES.
6. LOPE OVER POLES (LL).
7. BREAK TO THE JOG, JOG OVER POLES, JOG INTO AND STOP IN CHUTE.
8. BACK BETWEEN POLES, BACK INTO BOX.
9. EXECUTE A 360 DEGREE (TURN RIGHT). THEN WALK OUT BOX.
10. WALK OVER POLES.

2021 THE TEXAS FESTIVAL HORSE SHOW

JUNIOR L1,L2,L3 - SENIOR L1
AMATEUR L1 - YOUTH L1

SATURDAY APRIL 24TH

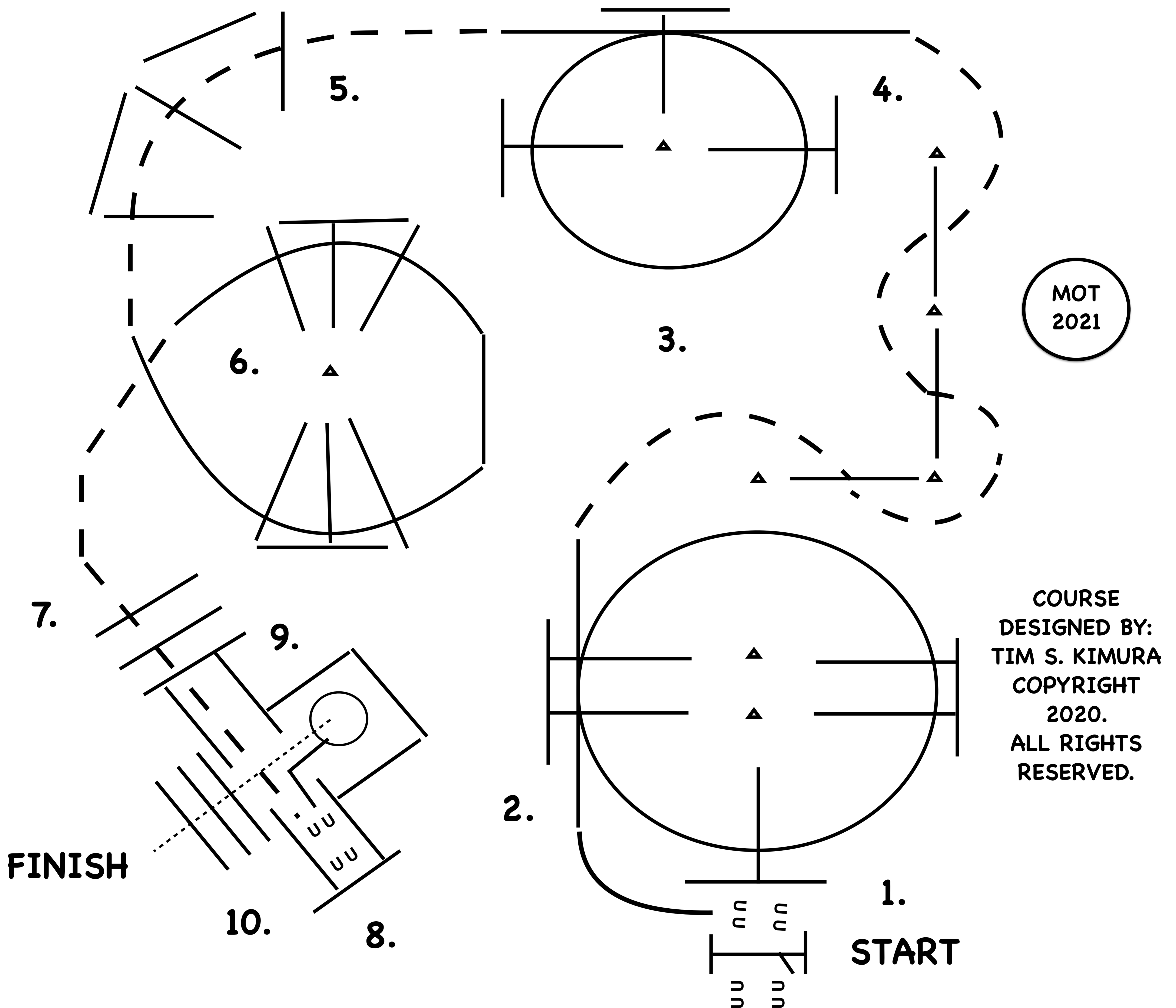

1. ROPE GATE: LEFT HAND OPEN, WALK OVER POLE CLOSE GATE
2. LOPE OVER POLES (RL)
3. BREAK TO THE JOG, JOG THROUGH SERPENITINE, JOG OVER POLES.
4. LOPE OVER POLES (LL).
5. BREAK TO THE JOG, JOG OVER POLES.
6. LOPE OVER POLES (LL).
7. BREAK TO THE JOG, JOG OVER POLES, JOG INTO AND STOP IN CHUTE.
8. BACK BETWEEN POLES, BACK INTO BOX.
9. EXECUTE A 360 DEGREE (TURN RIGHT). THEN WALK OUT BOX.
10. WALK OVER POLES.

2021 THE TEXAS FESTIVAL HORSE SHOW

SM FRY TRAIL
WT YOUTH - WT AMATEUR TRAIL

SATURDAY APRIL 24TH

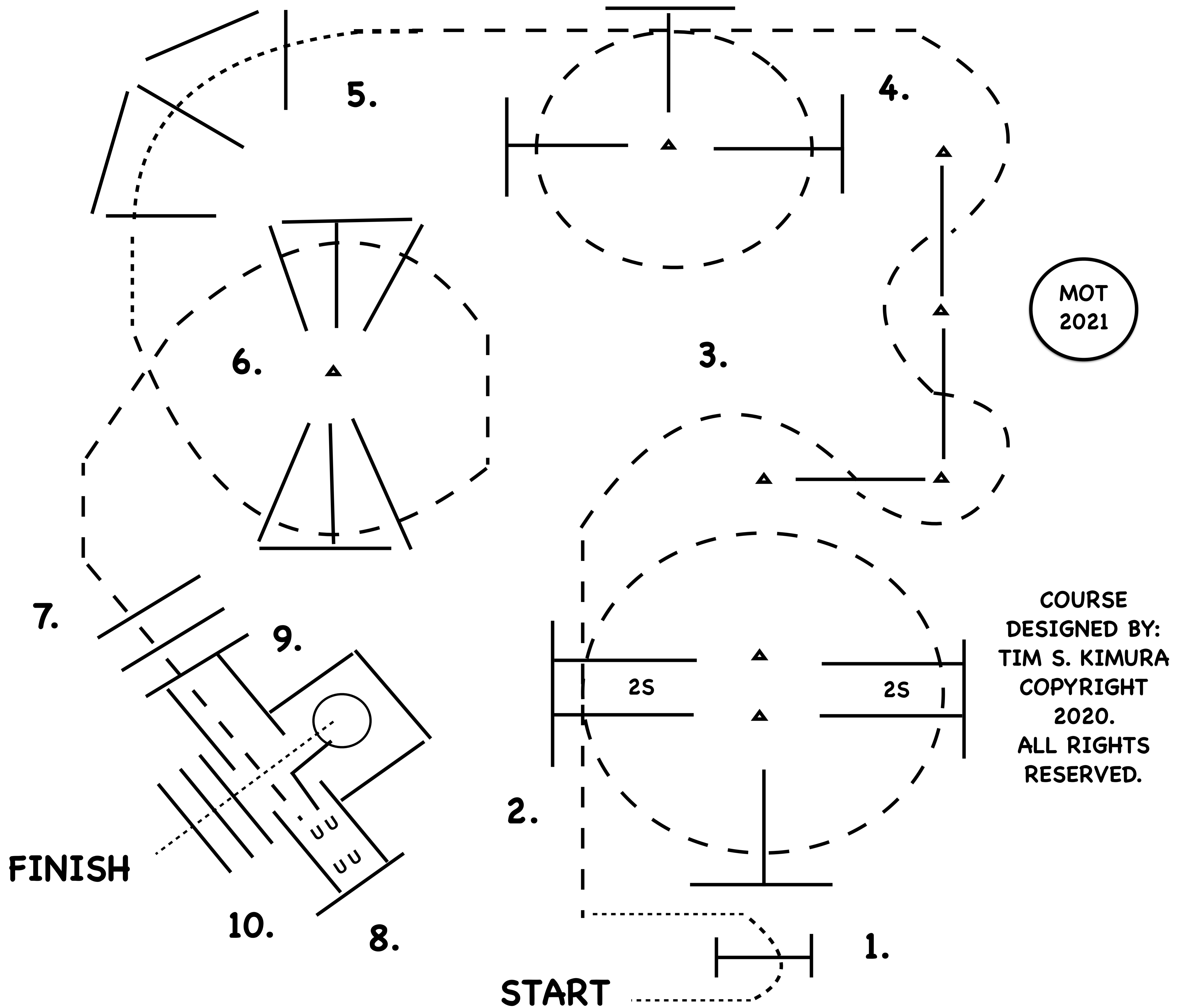

1. WALK OVER POLE, TURN RIGHT
2. JOG OVER POLES.
3. JOG THROUGH SERPENTINE,
JOG OVER POLES.
4. JOG OVER POLES.
5. STOP OR BREAK TO THE WALK,
WALK OVER POLES.

6. JOG OVER POLES.
7. JOG OVER POLES,
JOG INTO AND STOP IN CHUTE.
8. BACK BETWEEN POLES, BACK INTO BOX.
9. EXECUTE A 360 DEGREE EITHER WAY.
THEN WALK OUT BOX.
10. WALK OVER POLES.