

RUN FOR THE ROSES—MAY 6, 2018

Junior, Senior, Youth, Select Amateur, Amateur Trail

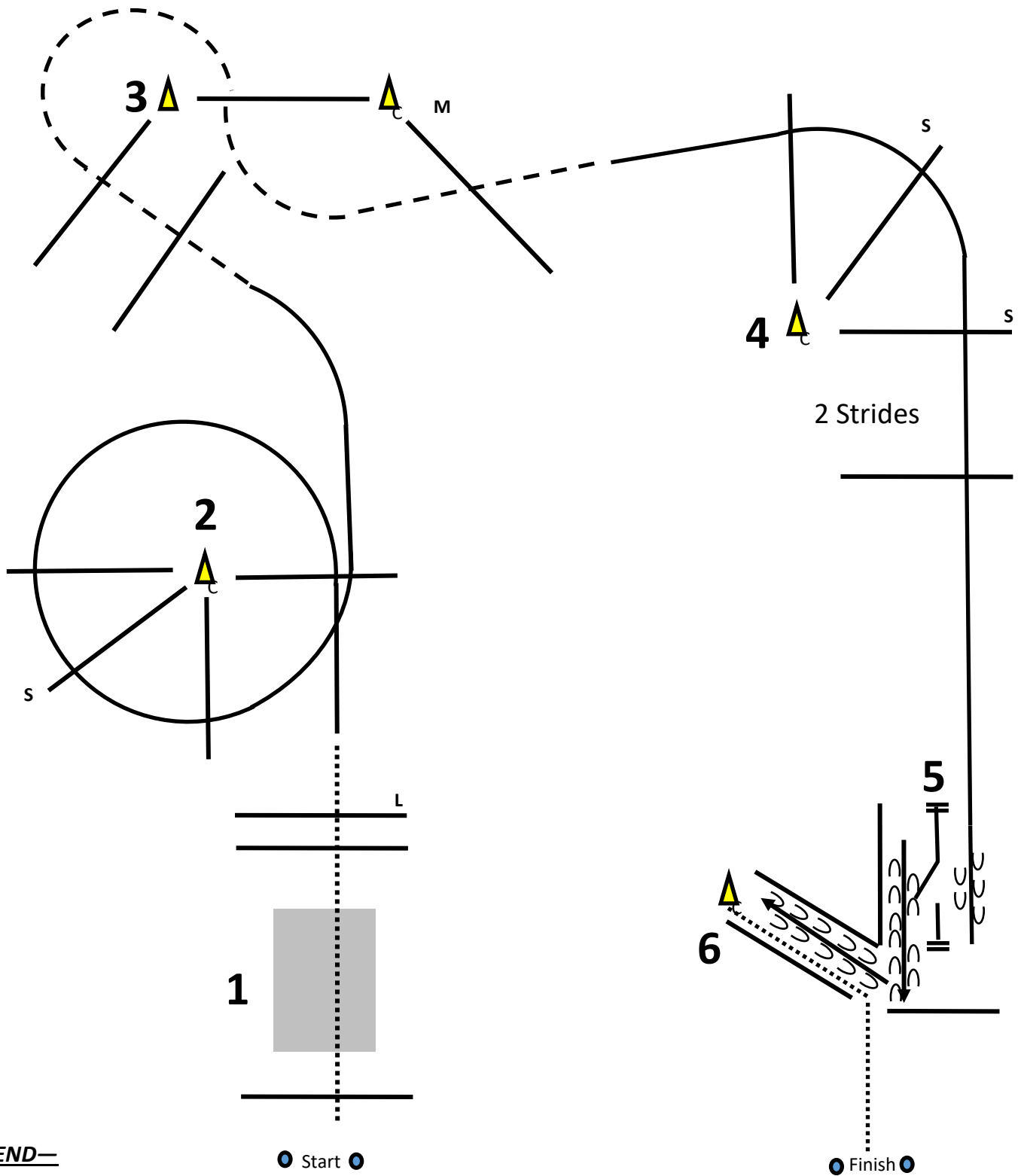

LEGEND—

WALK— →

JOG— - - - - - →

LOPE— ———— →

BACK— cccc →

- | | |
|---|---|
| <p>1. Walk over poles and bridge</p> <p>2. Left lead over poles</p> <p>3. Jog serpentine over poles</p> | <p>4. Right lead over poles</p> <p>5. Right lead to gate, stop, right hand gate</p> <p>6. Back chute, walk out of chute to exit</p> |
|---|---|